

Accouplé à C5 chariot à direction électrique (version perpendiculaire)
Fixed to C5 electric travel trolley (perpendicular version)
Mit C5 Motorfahrwerk (Quer zur Kettenzugachse)

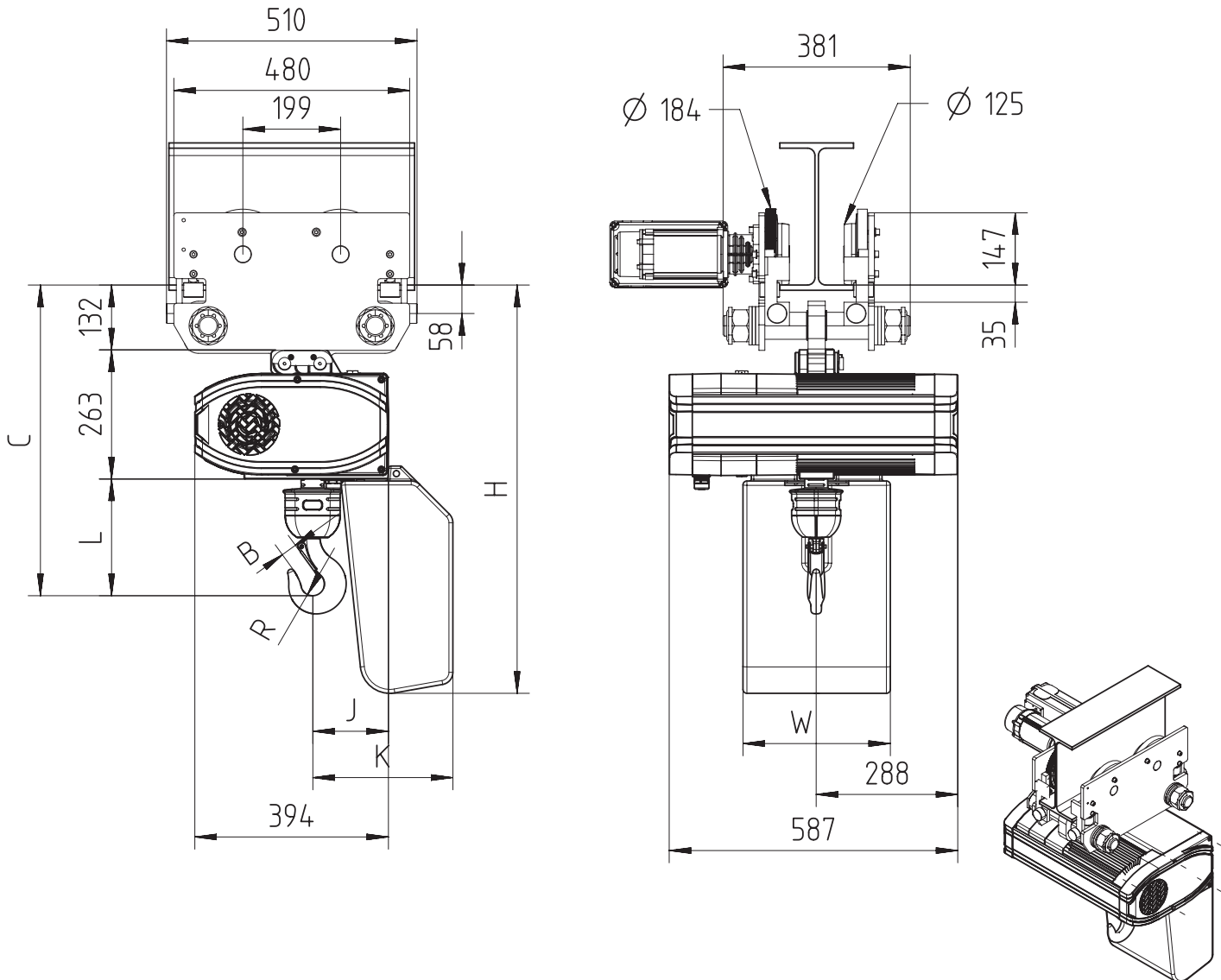

Chain Size [mm]	Falls	Chain bag max capacity [m]	Max load kg	Dimensions [mm]								Weights [kg]					
				B	C	L	R	J	K	H	W	M		Weight of 3m of chain	Total weight w/o chain		
												Classic/ GLS	Neo/ DB		Classic	Neo	GLS
11.3X31	1	12	2500	33	633	238	24	154	286	831	300	587	709	8.4	189.7		
11.3X31	1	30	2500						397	1008	350			8.4	189.7		
11.3X31	2	12	5000	41	783	388	28	203	334	831	300			8.4	193.4		
11.3X31	2	30	5000						447	1008	350			8.4	193.4		
9X27	1	12	1600	26	606	211	22	154	286	831	300			5.31	189.2		
9X27	1	30	1600						397	1008	350			5.31	189.2		

GLS = Gear Limit Switch
DB = Double Brake

SWF behält sich das Recht auf Veränderung oder Richtigstellung der oben genannten Information ohne weitere Mitteilung vor.

SWF reserves the right to alter or amend the above information without notice.

SWF se réserve le droit de modifier sans préavis les caractéristiques de son matériel.

DISCLOSED WITHOUT PRIOR WRITTEN CONSENT OF THE COMPANY . ANY COPIES OF THIS DOCUMENT MADE BY ANY METHOD MUST ALSO INCLUDE A COPY OF THIS LEGEND.